



TecBOS.Tech Software

Inventory management & organisation of technical service centres

TecBOS.Tech

TecBOS.Tech supports numerous types of workshop, e.g. for respiratory protection, portable instruments, fire extinguishers, vehicles, radio communications and hoses. It is an integrated system solution with maximum efficiency and transparency. The recording of equipment testing dates, upcoming services, as well as the storing of documentation relating to work carried out, spare parts used and test results is managed completely by TecBOS.Tech. By connecting to MSA test benches, the direct testing of equipment, without having to go through any intermediate steps, is made possible.

Benefit from the advantages of TecBOS.Tech:

- Predefined workshop and device structure
- Integrated RFID transponder and barcode technologies
- Intuitive data selection on all edit fields
- Easy extendable, modular structure
- Integration of mobile Windows CE devices (PDA)
- Microsoft Office conform export interface
- Crystal Reports interface for easy integration of self-designed print analysis and reports



Tailormade solution

With its configuration and settings, TecBOS.Tech is exactly suitable for the work processes and structures of your organisation. The open and flexible system portrays your requirements and processes 1:1. Detailed illustration of individual areas in the program structure and the provided data model delivers optimum results.

Easy entry

With TecBOS.Tech you can start immediately, no matter whether you start a new installation from scratch or transfer your already existing databases from another software solution. Thanks to the perennially extensible data- and/or module structure, you are flexible for longer duration.

Comfortable application

With the intuitive user interface, TecBOS.Tech supports every type of comfortable working in the network and on portable systems like Windows CE Handheld and TabletPC. The operation is intuitive and user-friendly. Predefined processes reduce incidental tasks to the minimum. These can be completed quickly and easily. Likewise, you also benefit from the high operational reliability and low system expenditure.

Economic use

By eliminating the isolated applications with high administrative expenses, you benefit from the TecBOS.Tech savings potential. The entire IT intricacy is aimed at saving your time. You can rely upon a quick startup and transparent and clearly presented work processes.

TecBOS.Tech is available in the bundles Standard, Professional and Premium. Choose the right software package for your requirements, no matter what's the area of application.

Tech.Standard

The basic solution for your respiratory protection workshop facilitates management of the entire data volume of executed and existing tests. With the integrated link-up to all MSA test benches (SmartCHECK, ProfiCHECK and MultiCHECK), you get an optimum platform for future tasks. The package includes all required basic modules for equipment testing, monitoring and invoicing of all executed tests incl. spare parts and service management. Additionally, Tech.Standard facilitates documentation of every equipment movement within an organisation or in external organisations.

Tech.Professional

With this expansion of the standard solution, complete equipment stock can be inventoried. In addition to the respiratory protection workshop, it is possible to create and manage other modules (workshops) freely. All basic functions of Tech.Standard are certainly available in Tech.Professional. Additional modules like interval monitoring, defect notification, multiple testing and preparation of data sheets can be integrated smoothly. Moreover, you get access to our optional add-on applications e.g. mobile working (PDA and laptop) for executing manual tests.

Tech.Premium

Our Tech.Premium bundle enables upgrading of equipment and/or clear spare part management by the functions of an inventory management system like inventory monitoring, inventory and overdue orders or goods receipts incl. appropriate stock item entry.

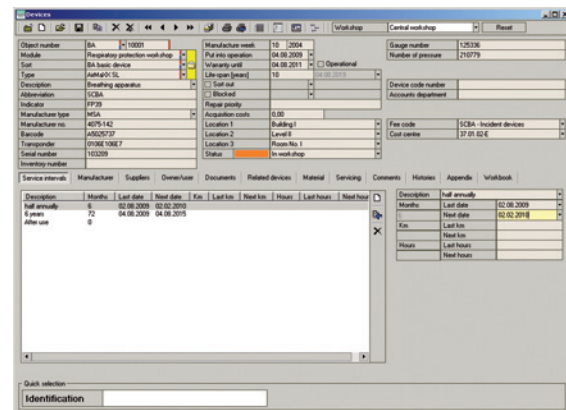

Device management

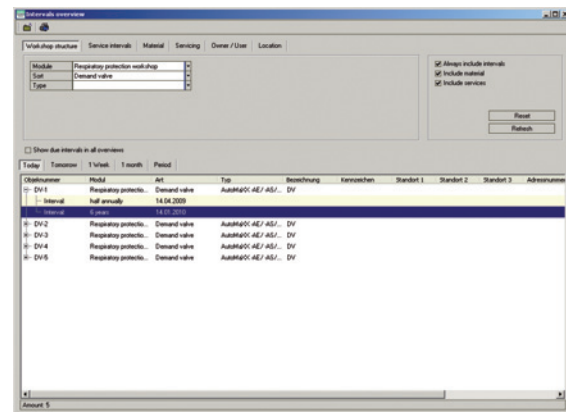

Intervals overview

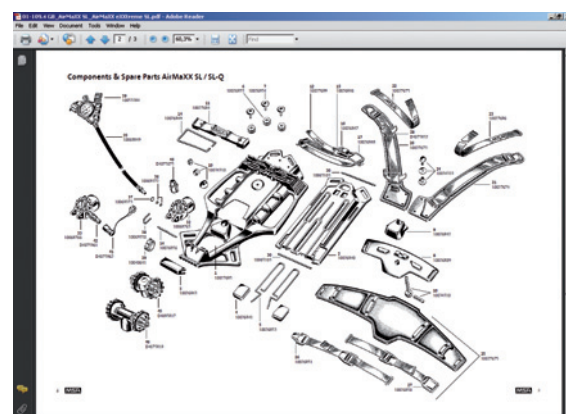

Integrated exploded view

TecBOS.Tech Standard

- Manual and automatic testing
- Preinstalled data pool
- Manufacturer independent predefined workshop structure (SCBA)
- Device management
- Interval administration
- Service management
- Article administration
- Address management
- Delivery notes, returns, invoices
- Cost centers
- Swap of devices

TecBOS.Tech Professional

- Open workshop structure
- Location management
- Defect notification
- Multiple testing
- Individual mask designer for additional data sheets
- Internal interval control module
- Barcode based delivery notes

These modules come in addition to the modules of TecBOS.Tech Standard.

TecBOS.Tech Premium

- Integrated warehouse management
- Ordering System
- Inventory
- Incoming goods

These modules come in addition to the modules of TecBOS.Tech Standard and Professional.

Add-Ons for Professional and Premium

- Mobile management – PDA with integrated transponder and barcode reader (swap of devices, mobile testing, multiple testing, equipment information)
- Mobile management – laptop
- Free selection of database system* (ORACLE, Microsoft SQL)
Interfaces to test benches of other manufacturers on request

*Corresponding software licences must be available.



TecBOS.solutions

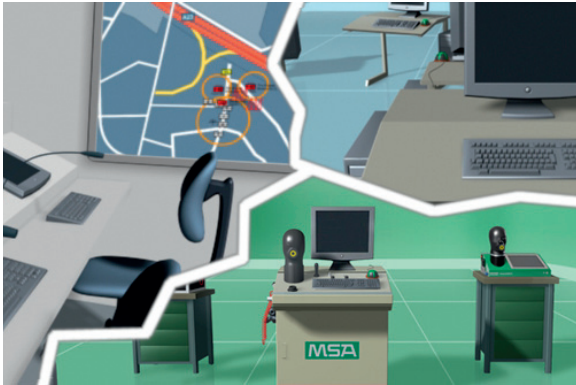

TecBOS.solutions is the software system for all public authorities, plant security and safety organisations. It was developed using MSA's extensive experience in the field to meet high safety standards, deal with new kinds of danger and, at the same time, to help work more efficiently. The performance efficiency of your personnel will be maximised through the automation of routine processes and the optimisation of operational procedures.

Three software product lines are available:

- **TecBOS.Tech** for technical service centres and workshops
- **TecBOS.Command** for emergency and incident management
- **TecBOS.Admin** for the administration of every area of your safety organisation

Thanks to the modular construction of TecBOS.solutions, every user can decide for oneself which product line is best for its own particular application. By this means, personnel and training administration, fire prevention, incident documentation and device management, among others, can be displayed in one complete solution.

Owing to its integrated hardware components, TecBOS.solutions is an optimal system solution that can be dovetailed into existing work processes. A range of MSA products, such as the automated test benches of the SmartCHECK series and the respiratory protection monitoring system alpha Personal Network, pass their data directly in the overall application without requiring additional interfaces. This results in minimum service effort and allows using the MSA platform in all areas of your organisation.

Integrated System Solutions

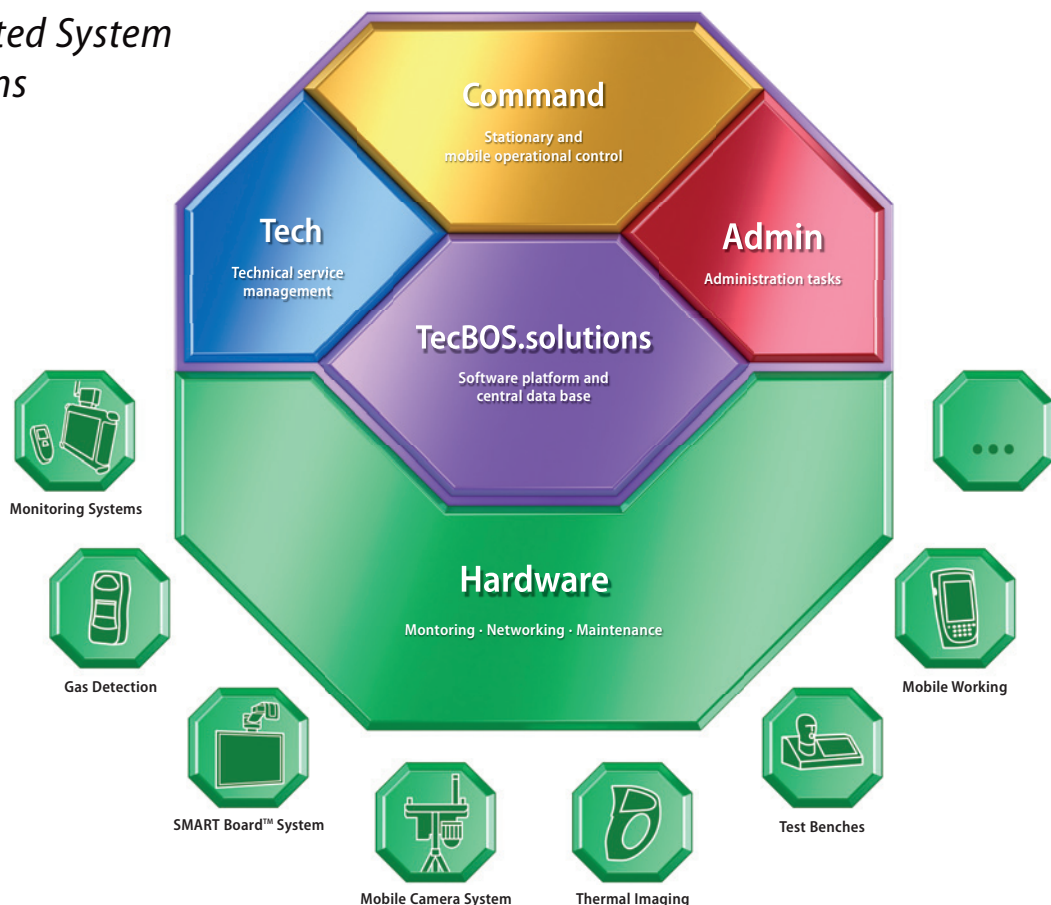

Before you decide

If you would like to find out how TecBOS.solutions can help optimise your organisation's processes, why not take advantage of MSA's free no-obligation TecBOS.solutions consultation. One of our trained specialists can help you analyse your particular situation and develop a TecBOS.solutions package to fit your operational requirements and budget. Our consultants work together with you as a partner to ensure that you choose a configuration that fits your needs today while planning for future development and applications.

Expert training and support

TecBOS.solutions is customised to your specifications at the time of installation. A highly intuitive interface and expert MSA training programmes ensures fast productivity on your new system. All TecBOS.solutions customers can take advantage of our online update service. Other options include a 24 hour service hotline and service contracts with free updates.

Ordering Information

TecBOS.Tech

10048780	TecBOS.Tech (Standard)
10053018	TecBOS.Tech (Standard) subsequent licence
10052539	TecBOS.Tech (Professional)
10053036	TecBOS.Tech (Professional) subsequent licence
10052540	TecBOS.Tech (Premium)
10053037	TecBOS.Tech (Premium) subsequent licence
10092495	TecBOS.Tech Ordering system
10092496	TecBOS.Tech Ordering System subsequent licence

Additional bundles, modules and add-ons upon request.



Your direct contact

MSA EUROPE Regional Head Offices & Great Britain (www.msa-europe.com)

Northern Europe
MSA Nederland B.V., Hoorn
Phone +31 (229) 25 03 03
E-Mail info@msaned.nl

Central Europe
MSA AUER GmbH, Berlin
Phone +49 (30) 68 86-0
E-Mail info@msa-auer.de

Eastern Europe
MSA Safety Sp. z o.o., Warsaw
Phone +48 (22) 711-50 33
E-Mail mee@msa-europe.com

Southern Europe
MSA GALLET, Châtillon sur Chalaronne
Phone +33 (474) 55 01 55
E-Mail message@msa-gallet.fr

International Sales
MSA EUROPE, Berlin
Phone +49 (30) 68 86-555
E-Mail contact@msa-europe.com

Great Britain
MSA (Britain) Limited, Bellshill
Phone +44 (16 98) 57 33 57
E-Mail info@msabritain.co.uk